

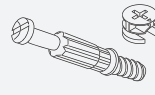









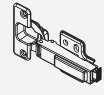



Hardware Included

		
Cam & Pin x 26	28mm Wood Screws x 4	Handle Screws x 2
		
Door Hinges x 2	Handle x 1	Adjustable Feet Screws x 16
		
Door Buffer x 2	Stick on Cam Cap x 6	Stick on Caps x 8
		
14mm Wood Screws x 16	1 Inch Nail x 20	90° Angle Bracket x 2
		
		Adjustable Feet x 4

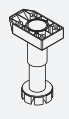
*Angle bracket is used to attach the benchtop to the cabinet.

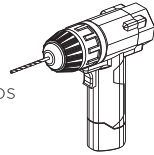
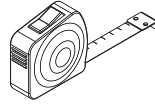
Tools you will need

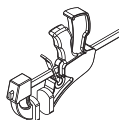
To put your cabinets together you will need the following tools.

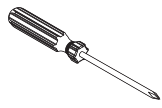
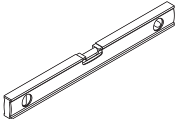
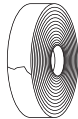
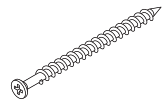
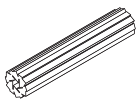
 Cordless drill with: • Number 2 Phillips head bit • 4.5mm drill bit • Number 12 countersinking drill bit	 Tape Measure	 Pencil	 Hammer	 Clamps (Quick Release)	 Safety Gear	 Phillips Head Screw Driver
 Spirit Level (900mm recommended)	 Masking Tape	 65mm Wood Screw	 Wall Fixing (If Necessary)			

Important notice

- Make sure you leave plumbing and electrical work to qualified trades people. Never try this yourself.
- If you have any questions, contact us on: **Australia: 1800 666 078** Monday to Friday between 8:00am and 6:00pm AEST, **New Zealand: 0800 522 663** Monday to Friday between 8:00am and 5:30pm NZST or email: info@flatpax.com.au



STEP 1

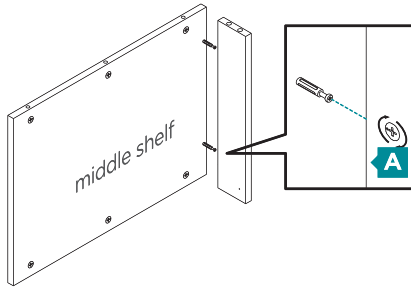

STEP 2

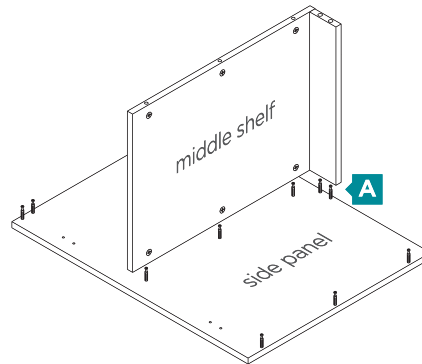

STEP 3

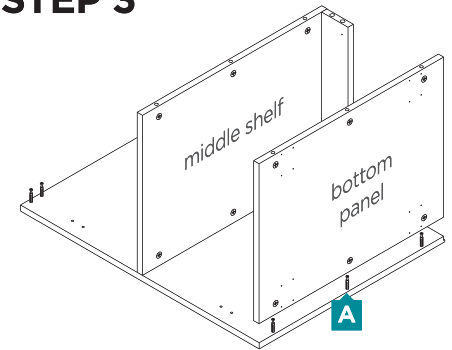

note: Make sure the pre-drilled holes for the adjustable feet are facing outwards.

STEP 4

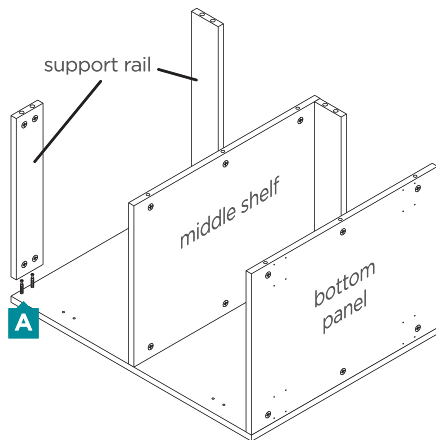

STEP 5

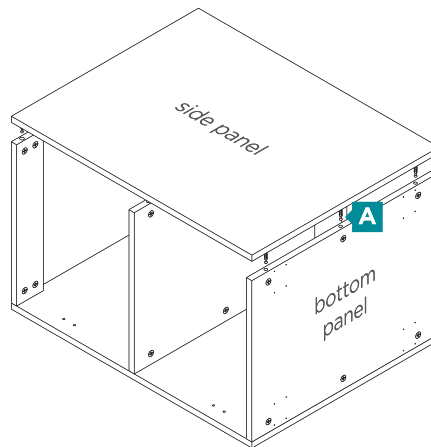

STEP 6

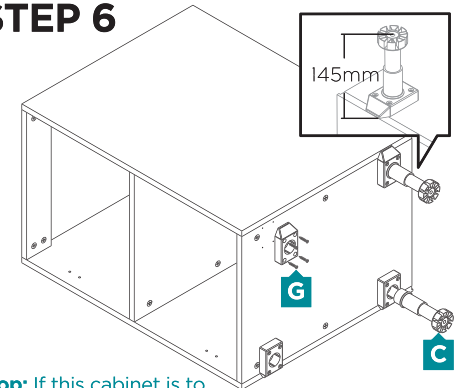

stop: If this cabinet is to be installed at the end of the run refer to the kickboard instructions now on the correct placement of the feet. Set the height of the adjustable feet to 145mm to suit the kickboard.

STEP 7

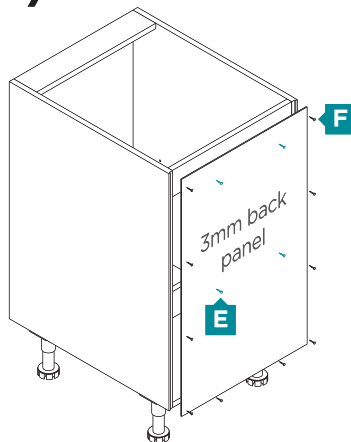

note: The white side of the back panel should face inside the cabinet.

STEP 8

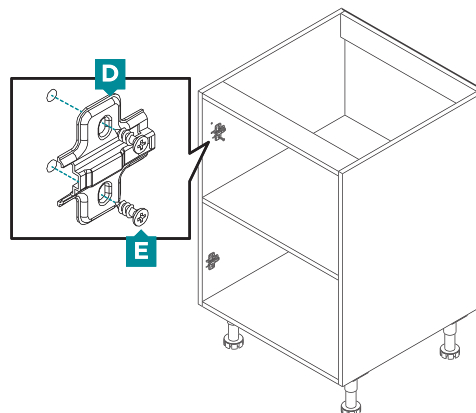

STEP 9

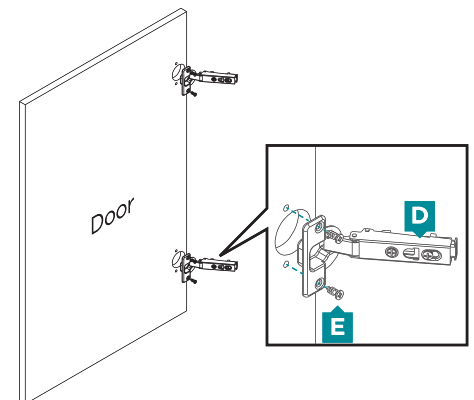

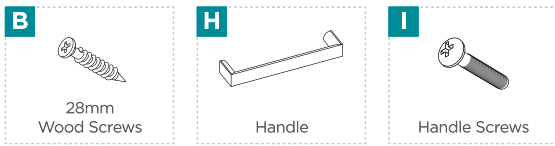

STEP 10

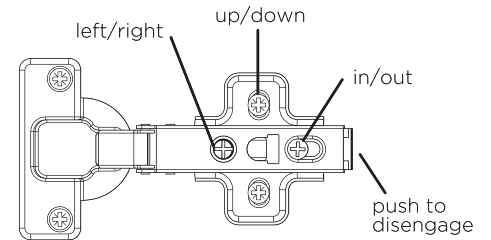
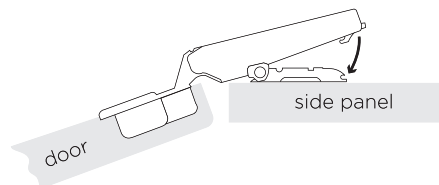
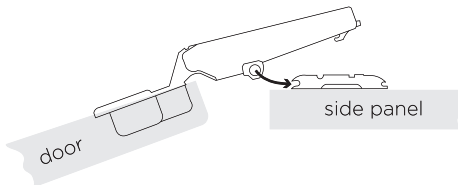

Clip the door onto the hinge plates.

Now push down to clip hinge securely together.

To align doors adjust marked screws.

STEP 11

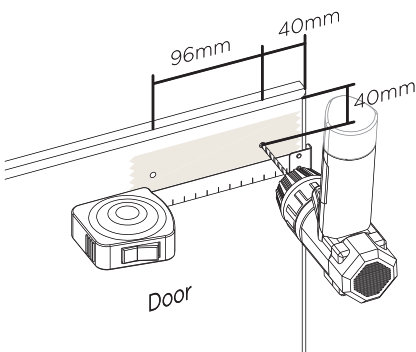

Place masking tape on both sides of the door where holes will be drilled to avoid chipping. Pre-drill using 4.5mm drill bit

STEP 12

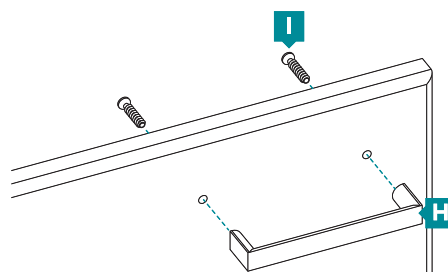

STEP 13

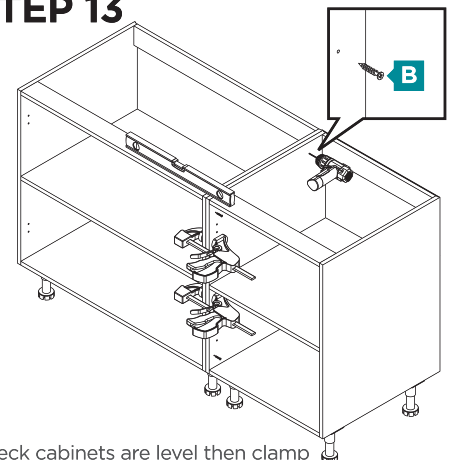

Check cabinets are level then clamp together. Pre-drill using 2mm drill bit and attach cabinets together.

STEP 14

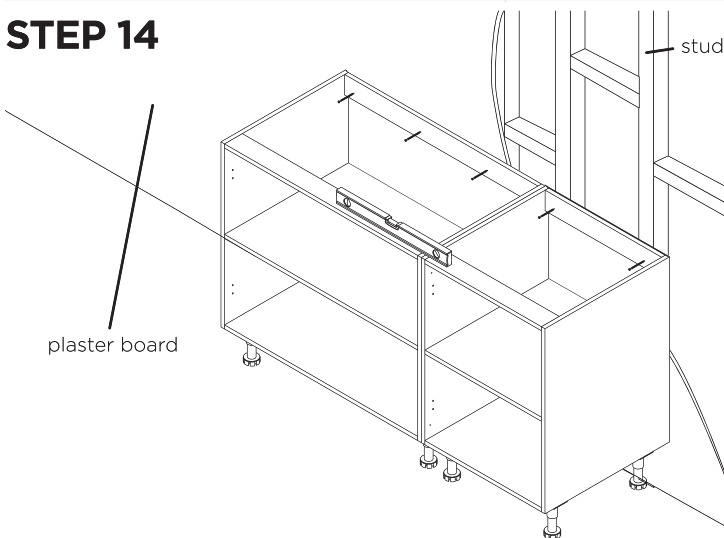

Caution: Please ensure all cabinets are screwed into your timber stud wall using a minimum of 65mm timber screws. If attaching to concrete, brick, steel or any other substrates seek advice from your hardware specialist.